

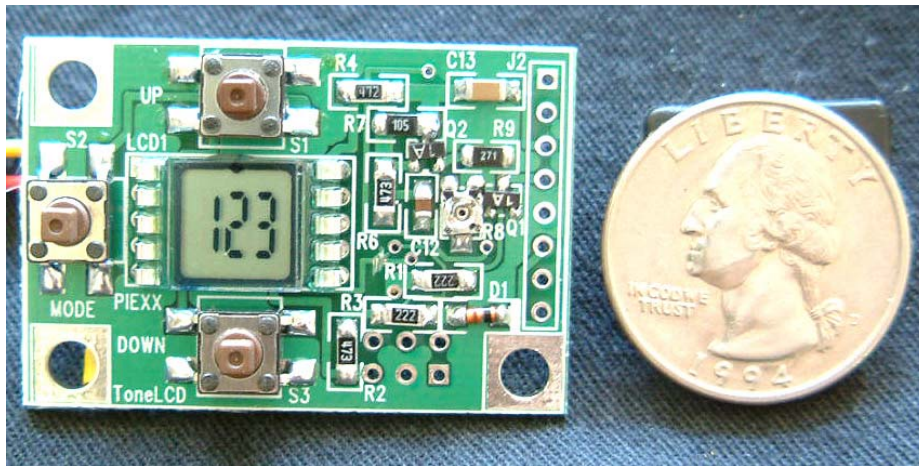

PIEXX Co.
13 Main Street
PO Box 123
Hillsboro, NH 03244
(603) 464-5411
www.piexx.com

PIEXX ToneLCD

Universal Direct Reading CTCSS Tone Encoder/Decoder



Introduction

If you are like me, you hate looking up dipswitch settings for tone encoder / decoder boards. The design goal that motivated the ToneLCD was to come up with a miniature, full feature CTCSS encoder / decoder that was easy to use. The ToneLCD is a small, 1.125 x 1.7 inches, easy to use, full-featured tone board that has a miniature LCD that displays the operating tone!

Features:

- Encoder / Decoder for both transmit encode and receive tone squelch decode operation.
- Find mode detects CTCSS tone that the receiver hears for automatic operation.
- Small size, 1.125 x 1.7"
- Low power consumption
- Operates from 4-15VDC
- Dedicated detect output as well as audio path switch.
- Easy to Operate
- Fully configurable Power Up State.

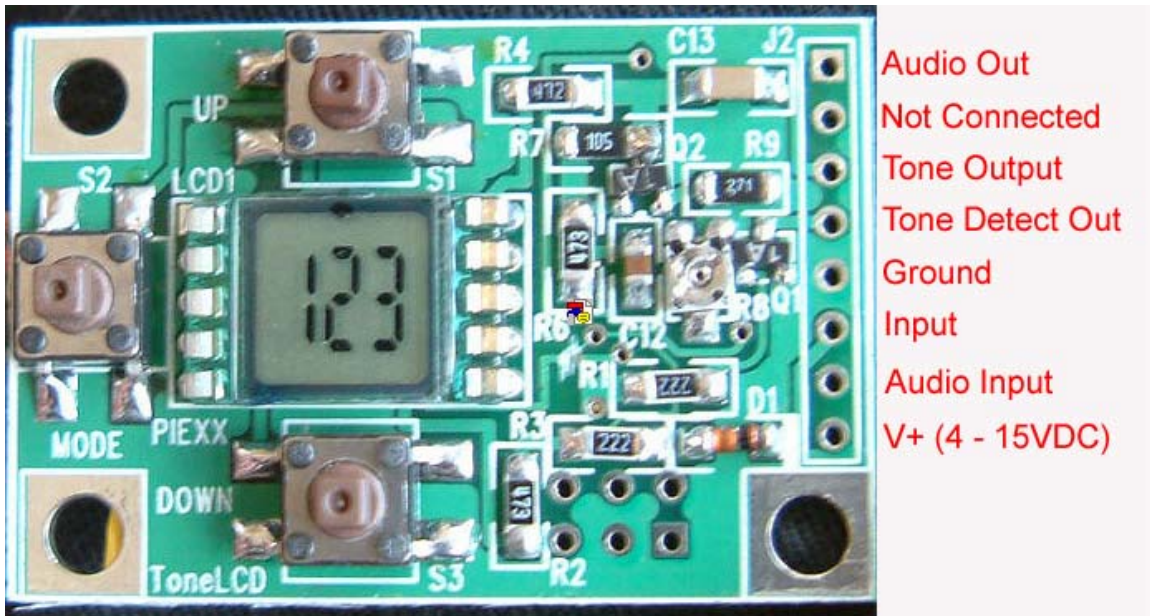

Connection to Transceiver

The pin out for J2, an 8 pin interface connector is as follows:

1. Receive Audio Output
2. No Connection
3. Tone Output
4. Tone Detect
5. Ground
6. Hang Up / Xmit Input
7. Audio In
8. Power 4-15 VDC

The power required for the ToneLCD is +4 to +15 VDC at approximately 18 mA. The power lead, pin 8 of J2 should be connected to a convenient switched supply within your transceiver. The return connection for the power is on J2 pin 5.

In order for the ToneLCD to operate in a tone squelch mode, it needs to sample the detected audio and provide a way to disable the audio path in the squelched condition. The ToneLCD provides an open collector transistor output that can be connected into your transceivers circuitry to enable or disable the audio path. An easier way to take care of both the tone input and squelch requirements is to connect the ToneLCDs audio in, J2 pin 7 and audio out, J2 pin 1, in series with the hot lead of your rigs volume pot. The ToneLCD has an audio switch in line with this audio path, and this switch is deactivated by the ToneLCD firmware when the tone squelch is activated and the correct tone signal is not seen. The connection in a typical transceiver is outlined in the schematic shown in figure 5. If you have no need for tone squelch, simply connect J2 pin 7 to the high side of the volume control and leave J2 pin 1 unconnected. If you do not connect the audio in

signal to the ToneLCD, the device will not be able to detect and report the CTCSS tone being used with its FIND mode.

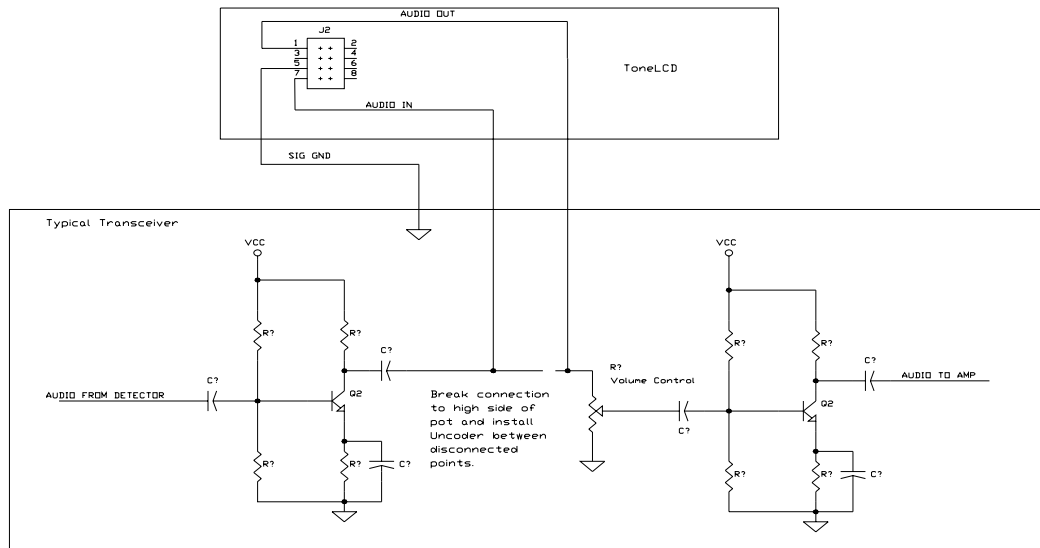

Fig. 1 ToneLCD Receive Audio Connection

The tone output is available from the Uncoder on connector J2 pin 3. If your rig has a connection point for a tone generator, you should connect the tone out to it. Otherwise, connect J2 pin 3 to a point in the transceivers close to the modulator and past the mic conditioning circuitry. The tone output level from the ToneLCD can be adjusted to about 1V RMS if necessary. Often a good point to inject the tone output is the high side of the deviation control. If you must connect the tone output to a point in the transceiver near the mic input you may need to install a series resistor in line with it to reduce the tone signal level so that it won't swamp out the modulator

The ToneLCD has an input signal, on J2 pin 6, that can be used as either a transmit detector input or a hang up switch input. If the input is used as a transmit detector, the CTCSS tone output will only be present when the input line is asserted. Alternatively if you have a mic holder that is switched, you can connect the input signal to it and when you unhook the mic the tone squelch will be defeated allowing you to hear the channels activity. If the input is used as a hang up, the receive audio path will be made, regardless of the presence of a valid CTCSS audio tone, whenever the input line is asserted. In the transmitter detector mode, P2 pin 6 should be connected to either the PTT line on your Mic plug, the transmit indicator light or a switched Xmit power connection. In the hang up mode, P2 pin 6 should be connected to your mic hang up switch. Don't worry about the polarity of the signals; the input polarity can be switched in one of the setup menus.

Set up

After you have installed the ToneLCD on your transceiver, and applied power, the display should show **tOn** briefly, and then it will show different information depending on how the ToneLCD has been set up.

You will need to adjust the setup parameters to match your hardware configuration. To enter the setup mode, press and hold the **MODE** button, for about 1 second, until the first setup parameter, **InH or InL**, appears. Once in the setup mode, you can cycle through the various setup parameters by momentarily pressing the **MODE** button (don't hold it, that gets you out of setup). Each time you press the **MODE** button, the program cycles to the next setup parameter. Pressing the **Up** or **Down** buttons will change the value of a parameter. The setup parameters are defined as follows:

- **In (H or L)** – This sets the active polarity of the Input signal line. L means low, and requires that the input signal be grounded to be active. H indicates that the active input state is high or floating.
- **In (r, t or -)** – This parameter sets the purpose of the input signal. **r** is for receive, or more specifically for hang up mode. **t** is for transmit, this allows the input to be used to enable or disable the CTCSS output tone. Finally, if this parameter is set to **-**, the input signal is unused.
- **tO (H or L)** - Tone Detect output state. If the tO state is set to L, the Tone Detect output will be pulled low in the presence of a valid CTCSS tone applied to the audio input. If the tO state is set to H, the Tone Detect output will be floating (high if you pull it up with a resistor) in the presence of a valid CTCSS tone applied to the audio input. The Tone Detect output is an open collector transistor output.
- **tSt** – This is a test mode that allows you to see the state of the input signal as well as letting you change the state of the Tone Detect Output signal. You enter the test state by pressing either the **Up** or **Down** buttons when the **tSt** display is shown. When you enter the test mode, the display will change to **I-O** where the I will be either a 0 or a 1, indicating the state of the input signal, and O will be either H or L indicating whether the output state is High (floating) or Low. Pressing the **Up** or **Down** buttons will flip the state of the Tone Detect Output. Pressing the **MODE** button will leave the test mode and the

display will revert back to showing **tSt**. If you leave the ToneLCD in the test mode for more than 60 seconds, the device will automatically leave the Setup mode without saving any changed parameters.

- **LCd** – This setup parameter is used to flip the LCD display upside down, as well as reversing the Up and Down switch functions. This is useful if you are mounting the ToneLCD in different orientations.
- **Axx** – Where xx is a number between 0 and 31. This value establishes the audio level passed between the Audio In and the Receive Audio Output pins. Maximum signal is achieved when a value of 31 is selected. A value of 0 completely attenuates the audio path.

You can exit the setup parameter menu by pressing and holding the **MODE** button for 1 second. This will cause the ToneLCD to retain the parameters you have just set. Alternatively, if you don't press any keys for a minute or so, the ToneLCD will automatically exit the setup mode, without saving the parameters.

Operation

The ToneLCD has 4 modes of operation selected by momentarily pressing the **MODE** button:

1. **Off** – No CTCSS tone transmitted and the receive path is enabled.
2. **t** – The CTCSS tone is transmitted but the receive tone squelch is disabled.
3. **tr** – Both CTCSS transmit and receive squelch modes are enabled.
4. If ---, or a blinking tone value is shown on the display, then the ToneLCD is in the FIND mode. In the FIND mode the ToneLCD samples the Audio In line and if it 'hears' a valid CTCSS tone on the receive audio it shows the values as a blinking set of digits on the display. If no valid CTCSS tone is sensed, --- is displayed. In the FIND mode, if a valid CTCSS tone is present for approximately ½ second, the ToneLCD's tone frequency is set to that tone. This allows a semi automatic mode of operation. If the ToneLCD finds a valid tone, the next time you key up you will be transmitting on that same tone.

When you are in the **Off, t or tr** operating modes, pressing the **UP** or **DOWN** buttons will cause the active CTCSS tone frequency to be moved

up or down in value. You can slew the tone up or down by pressing and holding the **UP** or **DOWN** buttons.

Pressing the **UP** or **DOWN** buttons, while in the FIND mode, will cause the ToneLCD to leave the FIND mode and enter the “transmit only” (**t**) mode.

After you have the ToneLCD set to the most convenient mode of operation, you can save this as the default power up state of the device by simultaneously pressing and holding the **UP** or **DOWN** buttons for 1 second. This save not only the tone frequency but the current mode of operation as the power on default.

<http://www.piexx.com/>